

Signal Commander with Signal Booster

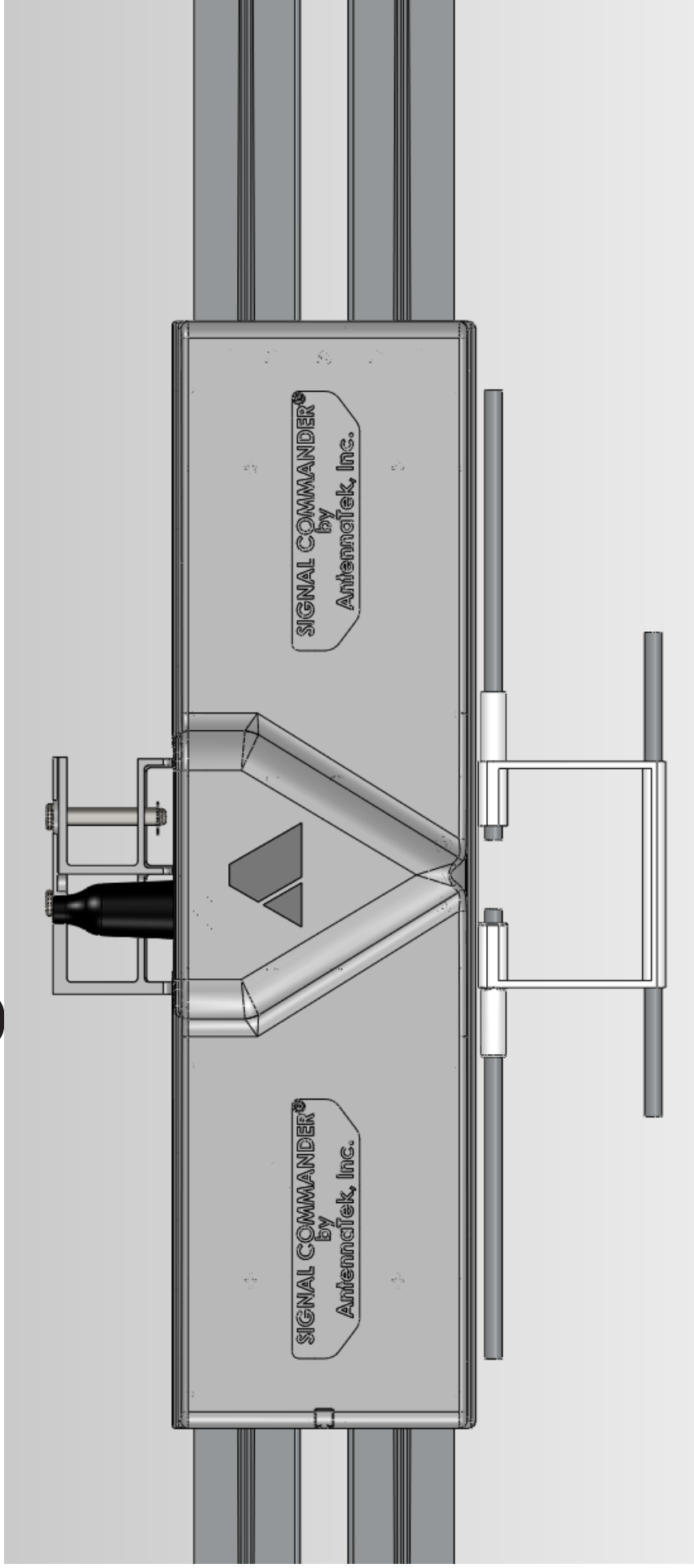

AntennaTek, Inc.

425 S. Bowen St., # 4
Phone: 303-772-9591

Longmont, CO 80501

FAX: 303-774-9533 www.antennatek.com

AntennaTek, Inc.

425 S. Bowen St., # 4, Longmont, CO 80501 Phone 303-772-9591

FAX 303-774-9533

Signal Booster Installation Instructions

Place the head assembly on a flat surface with the bottom cover facing up, align the pins on the signal booster with the holes on the bottom cover and press firmly.

Use the 4 screws provided(#4 x 5/8") to attache the signal booster to the head assembly.

See fig. 1 bellow

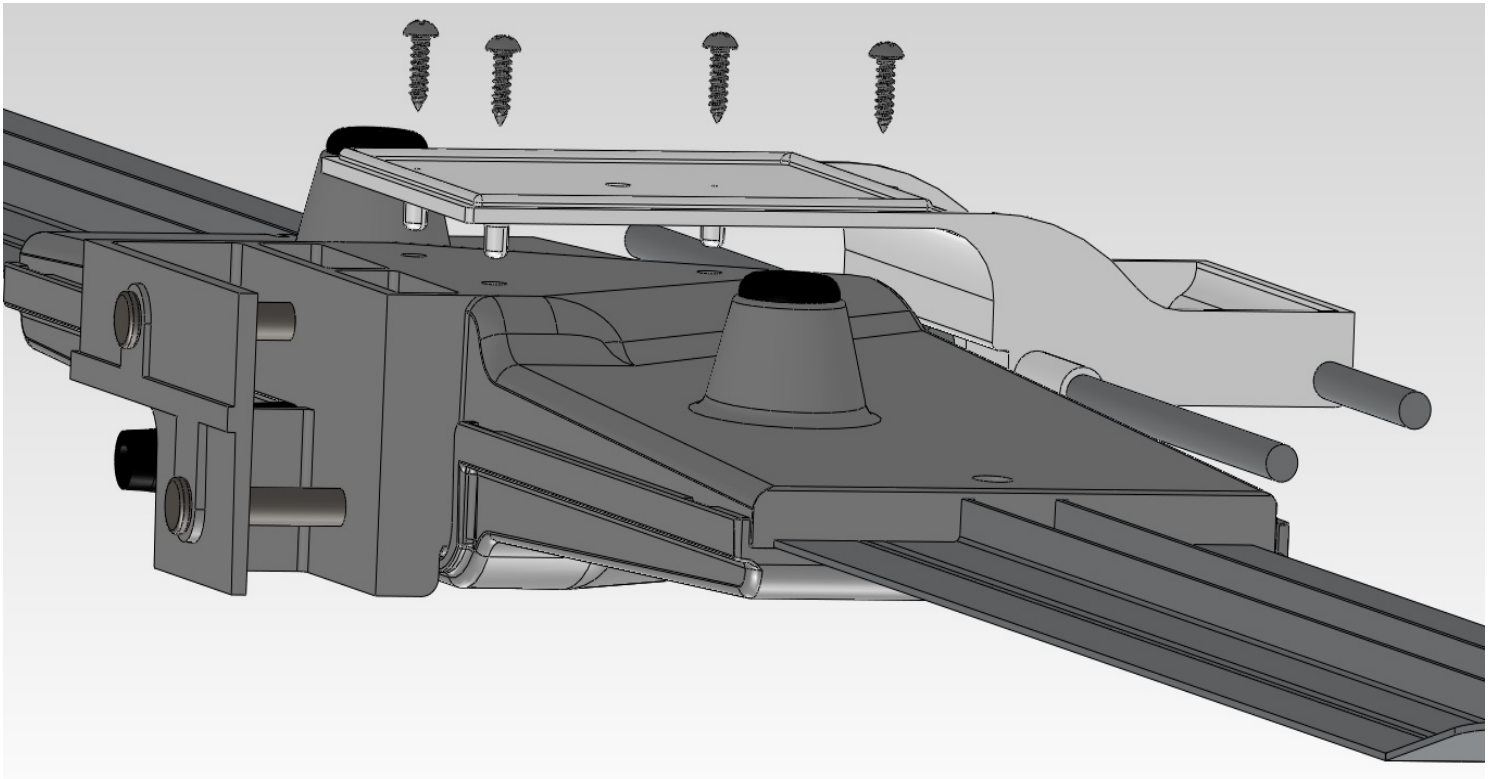

Fig 1